

# BETA 450E<sup>lectric</sup>

- MODEL 450E Combo -

## Electric FLOUR TORTILLA MACHINE

- Small Footprint
- Mobile
- Labor & Time Saving
- Runs Cleaner & Cooler
- No Gas or Ventilation Restrictions
- Great Carousal Display
- Easy 1 Person Operation
- Always provides consistent, freshly made flour tortillas and flatbreads

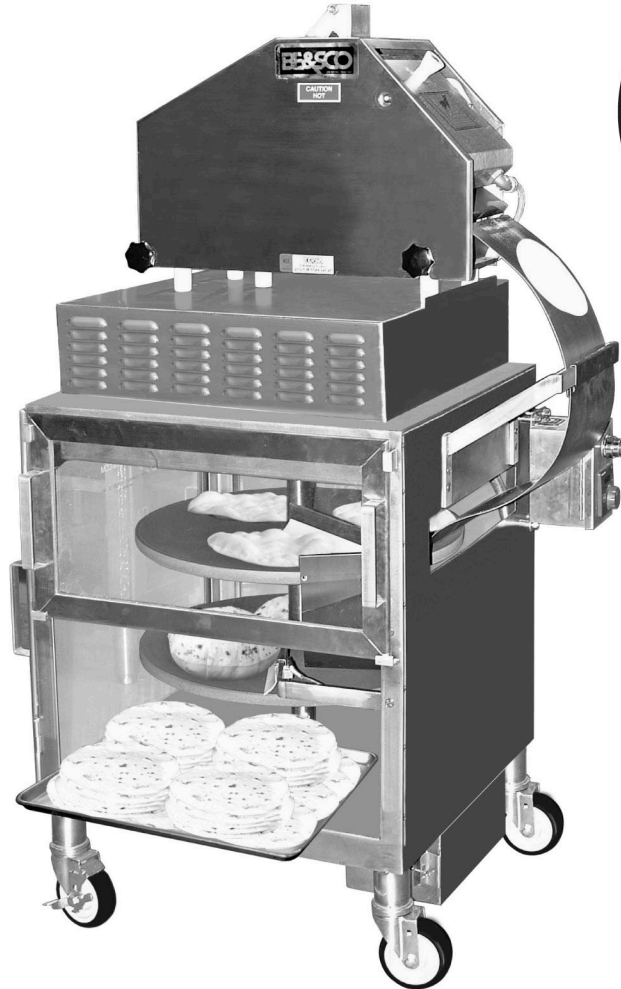

Produces up to  
**450**  
7" Flour Tortillas per hour\*\*



### SPECIFICATIONS Model 9AE (Press)

Electric: 120 VAC, 60 Hz,  
20 amps, Single Phase  
Length Press: 20.5"  
Width Press: 16.53"  
Height Press: 16.75"  
Weight: 70 lbs.

### SPECIFICATIONS Model 5 (Oven)

Electric: 240 VAC\*, 60 Hz,  
18 amps, Single Phase  
Length Oven: 26.5"  
Width Oven: 32"  
Height Oven: 37.5"  
Weight: 250 lbs.  
Patent pending 61/398,016



**1-800-683-0928**

[www.bescomfg.com](http://www.bescomfg.com)

\*\* Tortilla production will vary depending upon diameter and thickness of tortillas and the experience of the equipment operator.\*\*

\* You will need 240V to fully utilize the capabilities of the Beta 450E - less than 230V installation of buck and boost is required.

# BETA 450 E

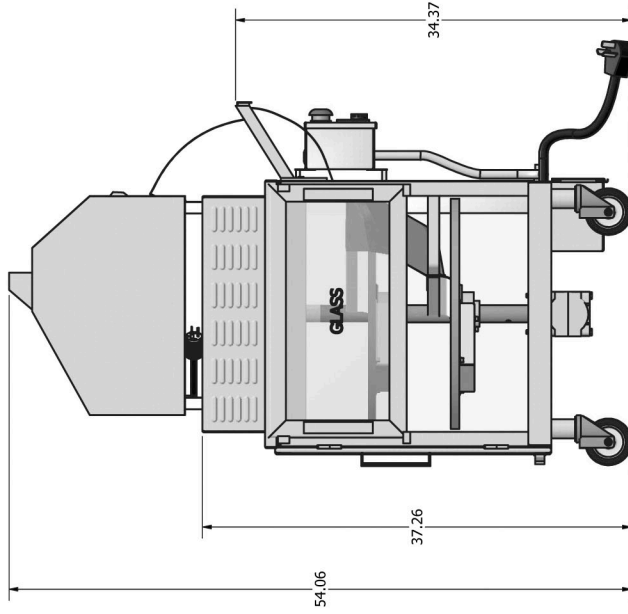
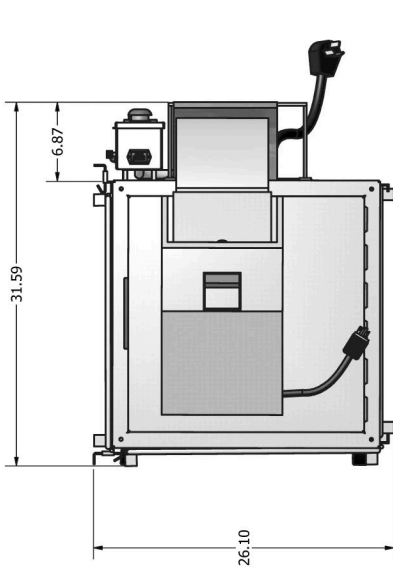
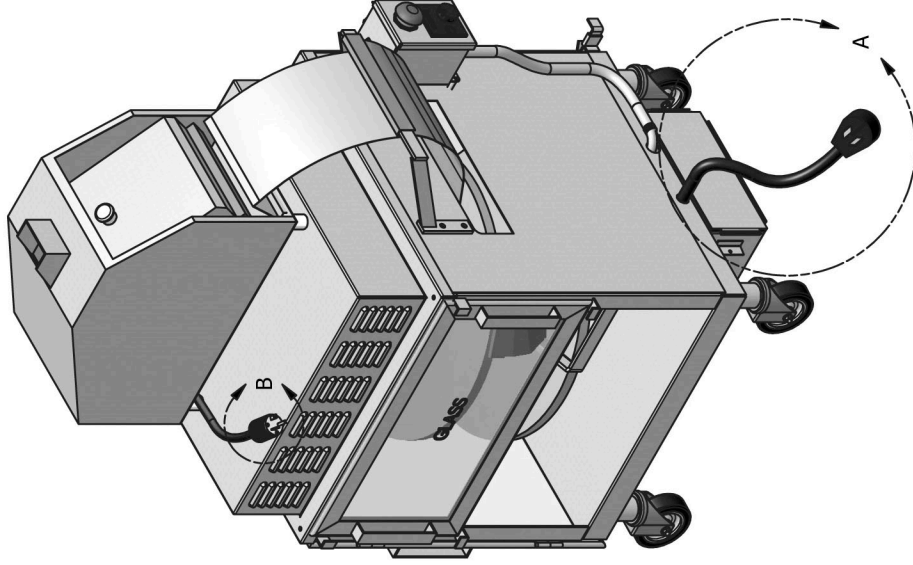
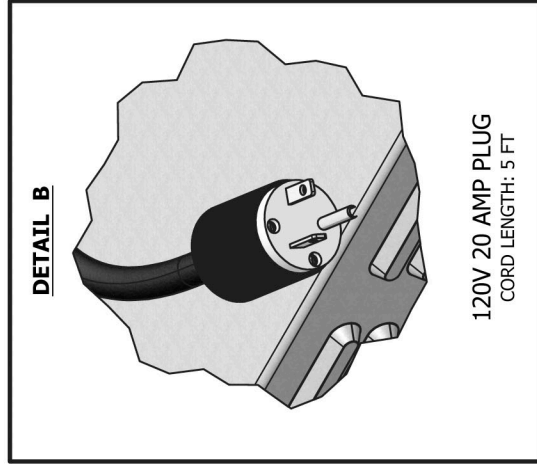
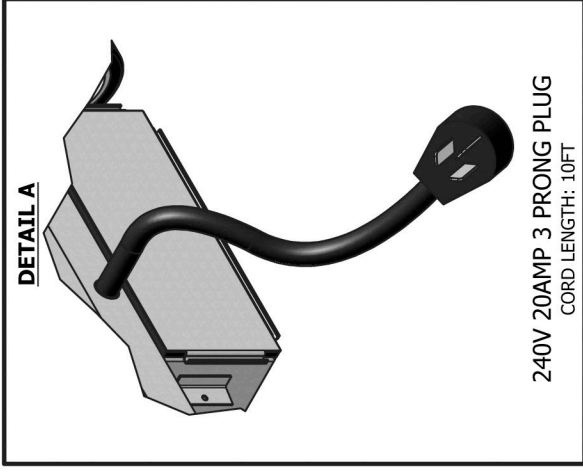

OVEN WEIGHT (NO WEDGE): 250 LBS  
 TOTAL WEIGHT WITH WEDGE: 320 LBS  
 PRODUCTION: 450 TORTILLAS PER HOUR  
 SA MIDWEDGE ELECTRICAL: 120V 20 AMP  
 OVEN ELECTRICAL: 240V 20 AMP